

Plug Style Balancing Valve

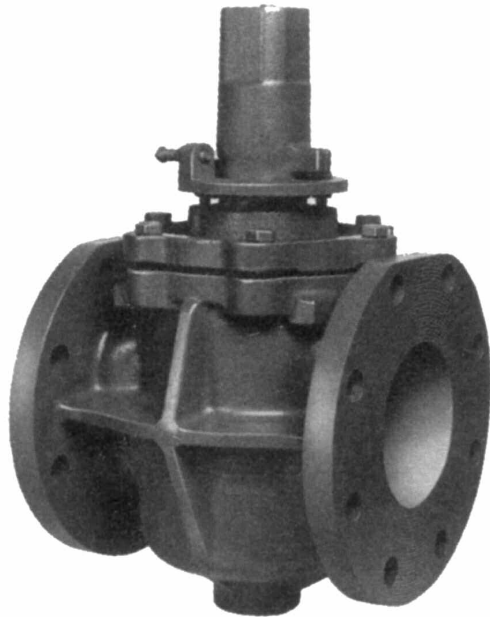

Features:

- Compact design, quarter turn operation
- Easy to read flow indication plate
- Gear operator handwheel standard on 10" and 12" models
- Lever standard on 2 1/2" and 3"
- Maximum working pressure of 175 psi
- Ideal for HVAC hydronic balancing
- Adjustable memory stop standard on 2 1/2" through 8"
- Schrader style test port connections for balancing
- Maximum working temperature of 250°F

Options:

- Gear operator lever available on 4" through 8" models (must be ordered separately)
- 2 1/2" through 4" available with NPT connections
- Grooved connections available

C_v Chart

Valve Size	C Values—Wide Open (Flow in GPM of Water at 1 psi pressure drop)
2 1/2"	236
3"	330
4"	560
5"	1180
6"	1180
8"	2030
10"	3130
12"	4140

Bill of Materials:

Part	Material
Body	Cast Iron
Plug Seal	Isobutene-Isoprene
Bearings	Stainless Steel
Packing	Buna

JOB NAME _____
 LOCATION _____

 CONTRACTOR _____
 CONTRACTOR P.O. NO. _____

ITEMS	QUANTITY
_____	_____
_____	_____
_____	_____
_____	_____
_____	_____

2 1/2" and 3" Valve Dimensional Data

Size	2 1/2"	3"
A	7 1/2"	8"
C	7/10"	3/4"
G	7 1/2"	9"
H	5 7/10"	6 2/5"
J	7"	7 3/4"
L	3 3/25"	3 22/25"
WT.	29 lbs.	42 lbs.

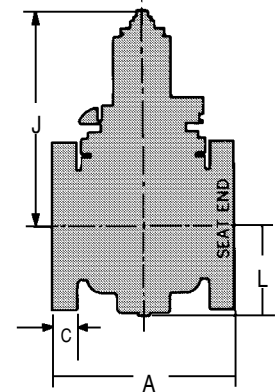
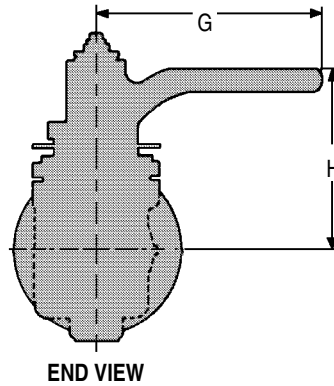

4" through 8" Valve Dimensional Data

Size	2 1/2"	5" and 6"	8"
A	9"	10 1/2"	11 1/2"
C	7/10"	3/4"	4/5"
G	14 3/4"	32 3/4"	43 1/4"
H	9 1/4"	12 22/25"	14 11/25"
J	10 1/5"	13 4/5"	15 2/5"
L	5 2/5"	6 1/2"	8 1/4"
Wt.	65 lbs	110 lbs	171 lbs.

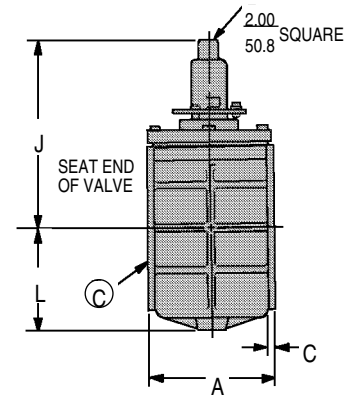
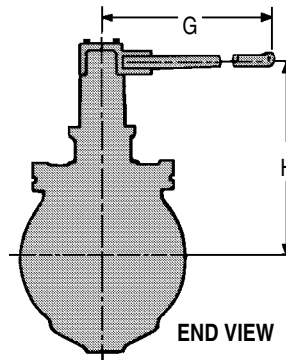

Please note: The "G" dimension (lever length) is based on a pressure drop of 25 psi for the 4" valve, and 100 psi for the 5" through 8" valves. For lever lengths with different pressure drops, consult factory.

10" and 12" Valve Dimensional Data

Size	10"	12"
A	15 3/25"	16 3/4"
B	19 22/25"	21 1/2"
C	8"	12"
D	3 3/4"	7"
E	11 3/25"	17 22/25"
S	9 22/25"	11 3/5"
T	13"	14"
U	22/25"	47/50"
Wt.	250 lbs.	390 lbs.

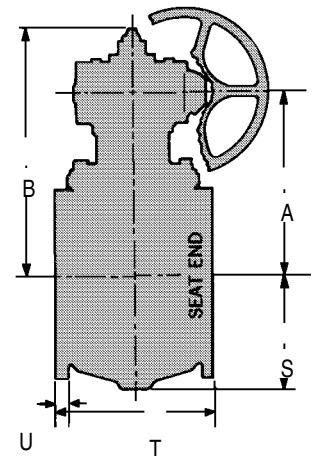
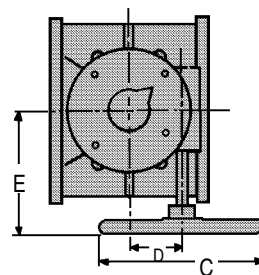

JOB NAME _____
 LOCATION _____

 CONTRACTOR _____
 CONTRACTOR P.O. NO. _____

ITEMS	QUANTITY
_____	_____
_____	_____
_____	_____
_____	_____
_____	_____