

Dual Disc Non Slam Check Valve

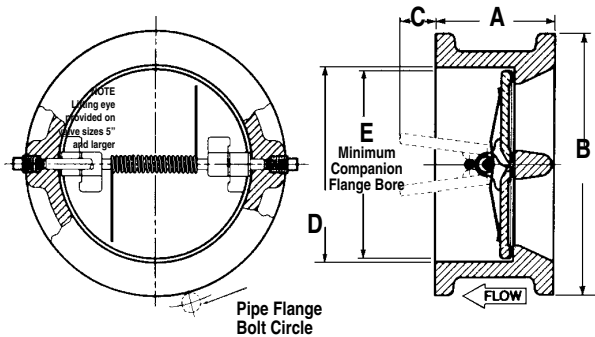

- Low head loss
- Compact wafer design
- Disc stabilization a 4 FPS
- Stabilized disc and stop pins
- Non-slam closing characteristics
- Lift and pivot disc action
- Drop tight seating at low and high pressures

Flow Coefficients

ANSI Pressure— Temperature Rating	
Max. Non-shock Pressure—PSI	
125 lb. Cast Iron 2" thru 16"	
150°F	200
200°F	190
250°F	175
Test Pressure	350

Valve Size	*Cv	Valve Size	*Cv
2"	80	8"	1700
2 1/2"	90	10"	3000
3"	150	12"	4000
4"	300	14"	5350
5"	500	16"	7400
6"	900		

*Cv = The number of U.S. Gallons/Minute of 60°F water that will flow thru the valve with a 1 PSI pressure drop across the valve.

Installation Dimensions

Valve Size	ANSI Class	A	B	C	D	E	Weight (lbs.)
2"	125/150	2 1/8"	4 1/8"	3/8"	2 3/8"	2 1/4"	4
2 1/2"	125/150	2 1/8"	4 7/8"	3/8"	2 15/16"	2 3/4"	6
3"	125/150	2 1/4"	5 3/8"	3/8"	3 1/2"	3 1/4"	6
4"	125/150	2 1/2"	6 7/8"	1"	4 1/2"	4"	12
5"	125/150	2 3/4"	7 3/4"	1 3/4"	5 3/4"	4 3/4"	15
6"	125/150	3"	8 3/4"	1 7/8"	6 1/2"	5 3/4"	20
8"	125/150	3 3/4"	11"	2 1/2"	8 7/8"	8"	38
10"	125/150	4 1/4"	13 3/8"	3 3/8"	10 1/2"	9 3/4"	56
12"	125/150	5 5/8"	16 1/8"	4"	12 1/2"	11 5/8"	98
14"	125/150	7 1/4"	17 3/4"	3 1/2"	14 1/2"	13 5/8"	145
16"	125/150	7 1/2"	20 1/4"	4 5/8"	16 1/2"	15 3/8"	186

Bill of Materials

Part Name	Material
Body	Ductile Iron
Disc	Stainless Steel
Seat Gasket	EPDM
Axle	Stainless Steel
Spring	Stainless Steel
Washer	TEFLON

	CLASS 125	CLASS 250
Normal Pressure	CLASS 125	CLASS 250
Sealing Test Pressure	255 PSI	398 PSI
Strength Test Pressure	348 PSI	543 PSI
Suitable Temperature C	NBR: 14° - +176°F	
	EPDM: 14° - + 248°F	
Medium	fresh water, sea water, waste water, food stuff	
	steam, oil, weak acid & alkaline liquid, etc.	

Silent Check Valve Threaded Style

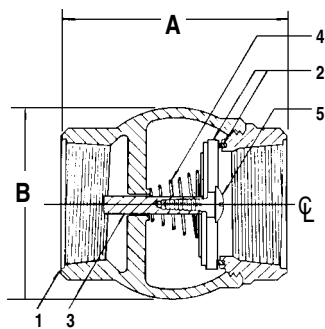

Dimensions

IPS	A	B
1/2"	2 1/16"	1 3/8"
3/4"	2 1/4"	1 5/8"
1"	2 5/8"	2"
1 1/4"	2 15/16"	2 3/8"
1 1/2"	3 15/16"	2 3/4"
2"	3 3/4"	3 3/4"

Design Data: Temp. 250°F —
Pressure 200 P.S.I.

Bill of Materials

Part No.	Part Name	Standard Material
1	Body	Bronze
2	Disc & Seat Ring	Teflon
3	Stem	Brass
4	Spring	Beryllium Copper
5	Seat Screw	Stainless Steel