

CHEMICAL BY PASS FEEDERS

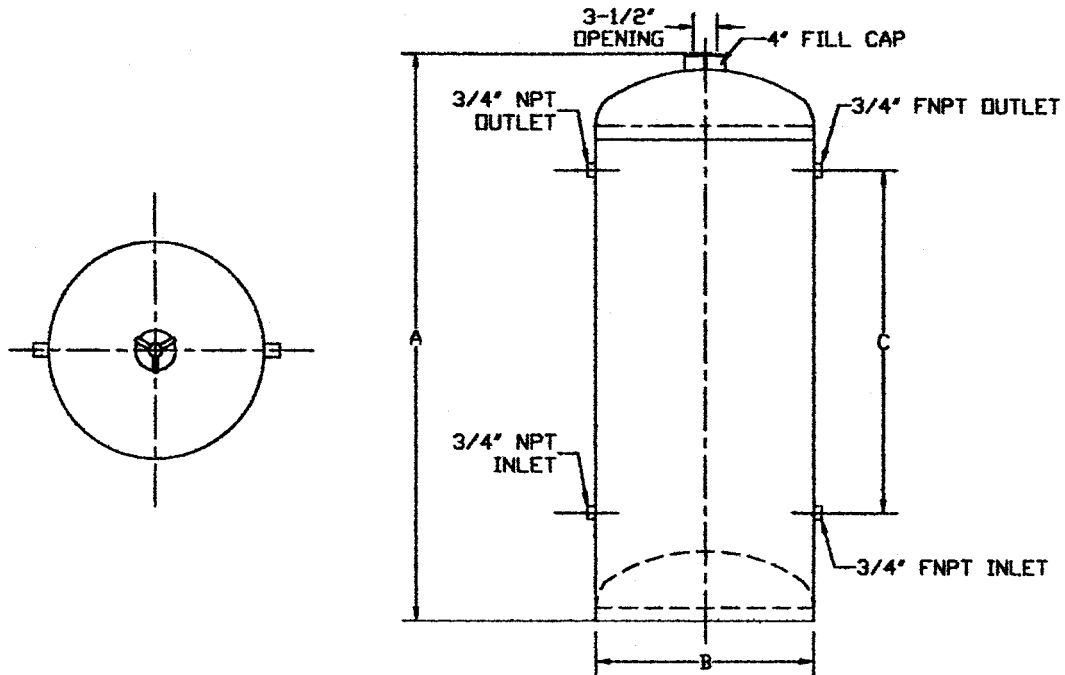

PART NUMBER	VOLUME	A (IN.)	B (IN.)	C (IN.)	WEIGHT	HEAD GAGE	SHELL GAGE
BFT-002X4	2 GAL.	21-1/4	6"	12-3/4"	23	11	11
BFT-005X4	5 GAL.	19-3/4	10"	10-1/2"	37	9	10

USE:

For water treatment in closed circulating water systems and boilers.
Great for use with chilled water treatment such as cooling systems and hot water treatment in heating systems.
Helps prolong life of heating and cooling systems.

SPECIFICATIONS:

Working Pressure rated at 300 P.S.I.
Caps are Easy Quick Opening
Bottom of Cap is Epoxy Coated for Liquid

Carbon Steel Construction
Self Supported Bottom
Coarse Thread with 2 1/2 Turn Design

JOB NAME _____
LOCATION _____

CONTRACTOR _____
CONTRACTOR P.O. NO. _____

ITEMS	QUANTITY
_____	_____
_____	_____
_____	_____
_____	_____
_____	_____