

EXPANSION TANK ACCESSORIES

PART NUMBER	CENTER DIMENSION	GLASS	PIPE SIZE
SG-008	8"	5/8"	1/2"
SG-010	10"	5/8"	1/2"
SG-012	12"	5/8"	1/2"
SG-016	16"	5/8"	1/2"
SG-020	20"	5/8"	1/2"
SG-022	22"	5/8"	1/2"
SG-028	28"	5/8"	1/2"

DESCRIPTION:

SIGHT GLASS ASSEMBLIES

SPECIFICATION:

ROUGH BRONZE VALVES
 WORKING PRESSURE RATED AT 200 P.S.I.
 MAXIMUM TEMPERATURE 400° F

Special Sizes available upon request

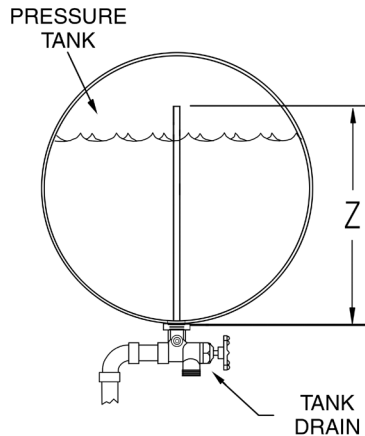

PART NUMBER	CONNECTION	TANK DIAMETER
TF-050	1/2" NPT	12" - 20"
TF-075	3/4" NPT	24" - 30"
TF-100	1" NPT	36" & UP

DESCRIPTION: COMBINATION VALVE & DRAINER

TANK FITTING ALLOWS SYSTEM WATER & AIR FLOW INTO EXPANSION TANK BUT PREVENTS AIR FROM ESCAPING

SPECIFICATION:

CARBON STEEL/COPPER TUBE
 WORKING PRESSURE RATED AT 125 P.S.I.
 MAXIMUM TEMPERATURE 240° F

JOB NAME _____
 LOCATION _____

 CONTRACTOR _____
 CONTRACTOR P.O. NO. _____

ITEMS	QUANTITY
_____	_____
_____	_____
_____	_____
_____	_____
_____	_____