

AIR SCOOPS

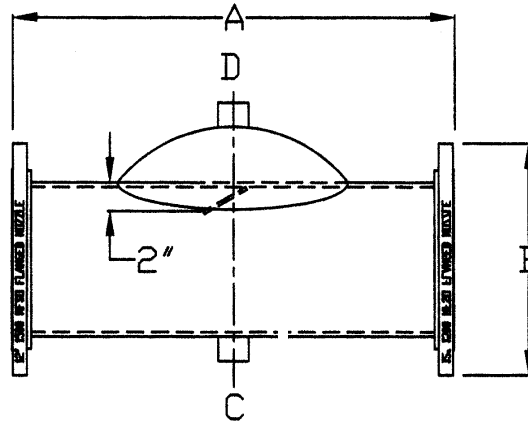

PART NUMBER	TSYSTEM CONNECTION	A(IN.)	B(IN.)	C(IN.)	D(IN.)	WEIGHT
AP-003	3"	12	8	3/4	3/4	42
AP-004	4"	12	9	3/4	3/4	51
AP-005	5"	15	10	1 1/2	1 1/2	65
AP-006	6"	18	11	1 1/2	1 1/2	83
AP-008	8"	24	13 1/2	1 1/2	1 1/2	135
AP-010	10"	30	16	1 1/2	1 1/2	235
AP-012	12"	36	19	1 1/2	1 1/2	352
AP-014 *	14"	42	21	1 1/2	1 1/2	435
AP-016 *	16"	48	23 1/2	1 1/2	1 1/2	525
AP-018 *	18"	54	25	1 1/2	1 1/2	650
AP-020 *	20"	60	27 1/2	2	2	825

*Non-stock Items

Larger Sizes can be fabricated to meet your needs. Please contact us.

For tangential air separators with and without strainers please see series ASL and ASW.

USE: For removal of entrained air in hydronic and pumping systems.

Helps prolong life of heating or cooling systems.

Provides protection against possible pipe damage and system noise.

SPECIFICATION:

Carbon Steel Construction

Maximum Temperature 345° F

Working Pressure rated at 150 P.S.I

Non A.S.M.E.

WE RECOMMEND ADDING OUR HIGH CAPACITY AIR VENT PART #ARO-75 FOR AUTOMATIC AIR REMOVAL. AIR VENT-CAST IRON BODY AND COVER, STAINLESS STEEL INTERNAL FLOAT AND ASSEMBLY.

JOB NAME _____
 LOCATION _____

 CONTRACTOR _____
 CONTRACTOR P.O. NO. _____

ITEMS	QUANTITY
_____	_____
_____	_____
_____	_____
_____	_____
_____	_____
_____	_____



A GFP Company

932 Brookwood Drive

Columbia, SC 29201

803.343.0710

TOLL FREE 866.267.1379

FAX 803.343.0713

www.mechanicalroomsupplies.com